



# Cat<sup>®</sup> AP355F PAVER

## TOP FEATURES:

### TECHNOLOGY THAT WORKS FOR YOU

- Powerful Cat<sup>®</sup> C3.3B engine meets regional emissions requirements
- Auto-fill feeder system simplifies setup
- Single touch feeder system activation optimizes efficiency
- Automated travel feature; augers and hydraulic mainframe extensions raise with the screed, preventing damage during transport
- Single-touch hopper control enables operators to concentrate on other duties
- Product Link<sup>™</sup> remotely monitors machine location, daily hours of operation, fuel consumption, fault codes, and preventative maintenance status, for optimal machine support

### EXCLUSIVE MOBIL-TRAC<sup>™</sup> UNDERCARRIAGE

- Excellent flotation, high-speed, and smooth travel
- Maintenance-free due to self-tensioning belt design
- Smoother paving results from oscillating bogies that crawl over grade deviations and limit tow-point movement for smoother paving

### UNMATCHED AFTER-THE-SALE SUPPORT

- Strategically located dealers with 24/7 support
- In-the-Iron service training for technicians
- Paver Operator Training helps maximize machine performance
- Project consulting helps improve technique and job site management

### LOW OWNING AND OPERATING COSTS

- Exclusive eco-mode and automatic engine speed control, reduce fuel consumption and lower sound levels for better comfort and communication
- Million cycle switches provide reliability
- Conveyor bed plates and chain guards designed to minimize labor requirements and provide lower cost replacement
- Heating elements slide-out for easy replacement
- Machined screed frames simplify screed plate leveling

### HIGH QUALITY RESULTS, HIGHER EARNINGS

- SE34 V and SE34 VT screeds available; vibration only or tamper-bar w/vibration
- Paving range of 700 mm (27.5") to 4600 mm (181")
- Electrically heated screed plates, easily replaceable
- Heated end gates help provide material smooth flow
- Quick extension installation/removal in ±30 minutes
- Variable frequency tamper bars and vibration systems help fine-tune performance

## Specifications:

### Weight

Tractor only	7100 kg	16,094 lb
w/SE34 V screed	8500 kg	18,850 lb
w/SE34 VT screed	8700 kg	19,246 lb

### Engine – Powertrain

Engine model*	Cat C3.3B		
Gross power:	55 kW	73.8 hp	74.8 metric hp
Number of cylinders	4		
Rated engine speed	2200 rpm		

\* Engine models are available to meet regional emission requirements including Brazil MAR-1 and China Stage III.

### Speed ranges:

Paving - vibratory screed	64 mpm	210 fpm
Paving - tamper-bar screed	25 mpm	82 fpm
Travel	0 - 11 km/hr	7 mph
Steering (outside)	1.65 m	5' 5"
Maneuver mode	500 mm	20"

### Paving Range

Standard range	1.75 - 3.42 m	5' 9" - 11' 2"
Maximum w/extensions	4.6 m	15' 1"
Reduction attachment	700 mm	27.5"
Screed vibration frequency	50 Hz	3000 vpm
Screed tamper-bar frequency	30 Hz	1800 vpm
Screed crown adjustment	+4.5% to -2.5%	

### Capacities

Maximum throughput capacity	406 Tonnes	447 Tons
Fuel tank	110 L	29.0 gal
Cooling system	9 L	2.4 gal
Engine oil	13.2 L	3.5 gal
Hydraulic tank	80 L	17.6 gal
Washdown spray tank	28 L	6.2 gal



## Dimensions:

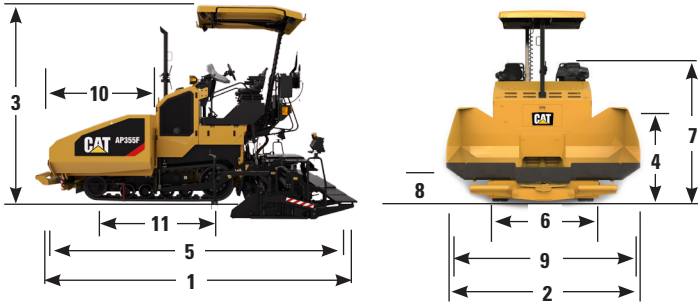

1 Overall length w/screed	5047 mm	(16' 6")
2 Operating width (hoppers lowered)	3180 mm	(10' 5")
3 Operating height	3415 mm	(11' 2")
4 Operating deck height	1313 mm	(4' 3")
5 Transport length w/screed	4904 mm	(16' 1")
6 Transport width w/end gates	1886 mm	(6' 2")
7 Transport height w/canopy retracted	2645 mm	(8' 8")
8 Truck entry height - hopper	547 mm	(21.5")
9 Truck entry width	3150 mm	(10' 4")
10 Hopper length w/push-roller	1993 mm	(6' 4")
11 Ground contact length	2055 mm	(6' 9")

### Cat C3.3B Engine

- Meets Regional Emissions
- Eco-Mode Saves Fuel

### High-Tech Machine Controls

- Single-Touch Feeder System
- Single-Touch Hopper Control



### SE34 VT and V Screeds

- Tamper Bars (VT) and Vibration
- Vibration only (V)

### Excellent Maneuverability

- Exclusive Mobil-Trac Undercarriage



Materials and specifications are subject to change without notice.  
 Featured machines in photos may include additional equipment.  
 For more complete information on Cat products, dealer services, and industry solutions, visit us on the web at [www.cat.com](http://www.cat.com)

QEHQ1962-02 (03-2017)

©2017 Caterpillar Inc.  
 All Rights Reserved.

CAT, CATERPILLAR, ACERT, SAFETY.CAT.COM, their respective logos, "CaterpillarYellow" and the "Power Edge" trade dress, as well as corporate and product identity used herein, are trademarks of Caterpillar and may not be used without permission.

